

Full-Port Control Valves CV30 Models

The CV30 control valve is a reliable, full-port control valve in a compact package featuring balanced plug control trim for excellent throttling or on/off control of fluids.

The adjustable topworks is designed to save space while leaving enough room to mount a controller. The soft-seat design achieves repeatable bubble-tight shutoff while remaining out of the flow path.

The CV30 is ideally suited for a wide range of applications with pressure control, level control or flow control.

The valve is available in a variety of material options and trim sizes. Metal-to-metal seat is available. A NACE option is available for sour service.



All trademarks and service marks used in this document are the property of their respective owners. This Beaumont Manufacturing and Distribution Co. product is exclusively distributed for new equipment packages by FW Murphy in the Natural Gas Compression market.

Specifications

Sizes: 2", 3", 4" and 6"

Connections: Female NPT (2" only), flanged

Body Type: Globe

Trim Characteristic: Modified % (throttling)

Trim Size: Full port and reduced port (1 size down)

Seat Types: Soft seat with metal-to-metal backup or metal-to-metal hard seat

Pressure Rating: See table

Temperature Range: -50° F to 300° F (-46° C to 149° C)

Shutoff:

ANSI Class IV Metal Seat

ANSI Class IV Soft Seat

Actuator Sizes:

2" CV30 - No. 70 (70 in² area)

3" CV30 - No. 120 (120 in² area)

4" CV30 - No. 120 (120 in² area)

6" CV30 - No. 120 (120 in² area)

Actuator Spring Ranges: 3-15 psi, 6-30 psi

Actuator Action:

Reverse (fail-close) & direct (fail-open)

Stem Travel:

2" CV30 - 1.00 in.

3" CV30 - 1.42 in.

4" CV30 - 1.76 in.

6" CV30 - 2.50 in.

Materials:

Body: WCC steel, LCC (low-temp option)

Packing Plug: A105 steel with nickel plating, A350 LF2 with nickel plating (low-temp option)

Trim:

Plug Ring: D2 tool steel (standard), 316 stainless (optional), carbide (optional)

Plug Tip, Seat Ring: D2 tool steel, 316 stainless (optional)

Seat: Polyurethane, low-temp HNBR (optional)

Cage, Plug and Stem: 316 stainless

Actuator Housing: Carbon steel

Yoke: A395 ductile iron

Bolting: A193 B7

Seat Detail

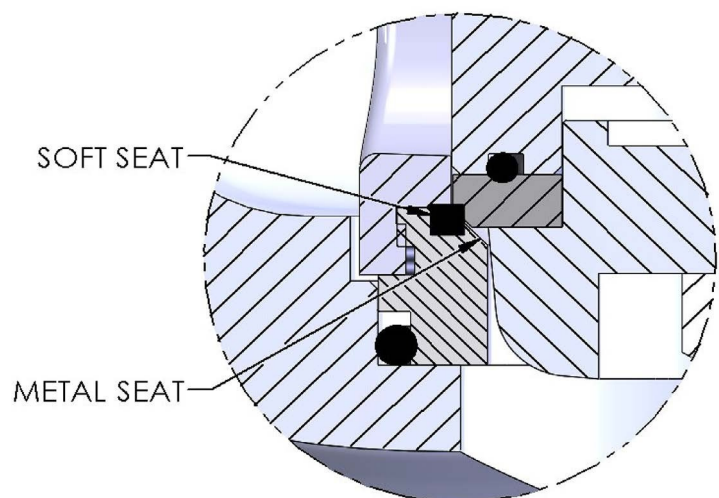

Cv Valves

Body Size	Trim Size (in.)	CV30 Valve Opening (% Travel)									
		10	20	30	40	50	60	70	80	90	100
2 Inch	1.5	0.8	3.6	6.6	9.2	16.5	23.5	26.2	27.4	29.3	29.8
	2.0	0.8	3.5	8.4	16.6	25.5	31.5	36.0	41.1	46.0	47.7
3 Inch	2.0	6.9	8.8	9.7	11.0	18.6	33.9	42.5	49.1	50.0	50.1
	3.0	4.4	6.0	11.7	33.1	37.3	68.0	76.5	99.3	108.0	117.9
4 Inch	3.0	4.2	10.3	17.0	22.4	27.3	44.6	70.3	89.3	106.0	111.3
	4.0	10.3	14.1	16.4	29.9	64.7	97.9	104.4	120.6	145.4	155.0
6 Inch	4.0	11.8	22.4	33	75.2	124.2	159.4	189	218.8	224.6	229.2
	6.0	21.6	44.0	93.0	183.0	262.4	292.0	317.4	348.2	378.6	390.6

Pressure Ratings

CV30 Body Size	2" NPT	150# Flange	300# Flange	600# Flange	900# Flange	1500# Flange
2 Inch	3900 PSI	285 PSI	740 PSI	1480 PSI	2220 PSI	3750 PSI
3 Inch	-	285 PSI	740 PSI	1480 PSI	2220 PSI	3750 PSI
4 Inch	-	285 PSI	740 PSI	1480 PSI	2220 PSI	3750 PSI
6 Inch	-	285 PSI	740 PSI	1480 PSI	-	-

Materials

CV30	Standard	NACE Compliant	Low Temp	Low Temp NACE
Component	ASTM A216 WCB	ASTM A216 WCB	ASTM A352 LCC	ASTM A352 LCC
Body	ASTM A395	ASTM A395	ASTM A395 ASTM	ASTM A395 ASTM
Actuator	ASTM A105	ASTM A105	A350 LF2 ASTM	A350 LF2 ASTM
Bonnet	ASTM A105	ASTM A105	A350 LF2 316	A350 LF2 316
Packing Plug	316 Stainless	316 Stainless	Stainless	Stainless
Stem	316 Stainless	316 Stainless	316 Stainless	316 Stainless
Cage	316 Stainless	316 Stainless	316 Stainless	316 Stainless
Plug	ASTM A681 D2	316 Stainless	ASTM A681 D2	316 Stainless
Seat Ring	ASTM A681 D2	316 Stainless	ASTM A681 D2	316 Stainless
Plug Ring	ASTM A681 D2	316 Stainless	ASTM A681 D2	316 Stainless
Seat Tip	17-7PH Stainless	Inconel X-750	17-7PH Stainless	Inconel X-750
Packing Spring	Nitrile	Nitrile	Nitrile	Nitrile
Diaphragm	PTFE	PTFE	PTFE	PTFE
Packing	Nitrile	Viton	Low Temp HNBR	Low Temp HNBR
O-Rings	Polyurethane	HNBR	Low Temp HNBR	Low Temp HNBR

Service Recommendations

CV30	Plug	Ring	Service	Do Not Use In
Material D2 Tool Steel			Abrasive Service	Sour Service, CO2, Steam
316 Stainless			Corrosive Service, NACE, Steam	Abrasive/Erosive Service
Tungsten Carbide			Corrosive Service, Abrasive, NACE	

Dimensions

CV30 Body Dimension												
End Connection	2" Globe Body			3" Globe Body			4" Globe Body			6" Globe Body		
	A	B	C	A	B	C	A	B	C	A	B	C
NPT	11.25	3.50	6.05	-	-	-	-	-	-	-	-	-
150RF	10.0	3.50	6.05	11.75	4.50	7.45	13.88	5.62	6.18	17.75	7.60	11.46
300RF	10.5	3.50	6.05	12.50	4.50	7.45	14.50	5.62	6.18	18.62	7.60	11.46
600 RF	11.25	3.50	6.05	13.25	4.50	7.45	15.50	5.62	6.18	20.00	7.60	11.46
600 RTJ	11.38	3.50	6.05	13.38	4.50	7.45	15.63	5.62	6.18	20.13	7.73	11.59
900 RF	13.38*/14.75	3.50	3.50	15.50	4.50	7.45	17.00	6.00	6.18	-	-	-
900 RTJ	13.51/14.88	3.63	3.63	15.63	4.63	7.58	17.13	6.13	6.31	-	-	-
1500 RF	13.38*/14.75	3.50	3.50	-	-	-	-	-	-	-	-	-
1500 RTJ	13.51/14.88	3.63	3.63	-	-	-	-	-	-	-	-	-

* Short Pattern Body Dimension

CV30 Actuator Dimensions (in.)						
Actuator Size	Direct			Reverse		
	F	G	H	E	F	H
No. 70, 3-1512.50	17.10	8.00	17.45	12.50	14.77	17.45
No. 70, 6-3012.50	20.06	8.00	19.45	12.50	16.37	19.45
No. 12016.00	21.54	8.90	20.67	16.00	17.30	20.67

Clearance needed for spring cover removal

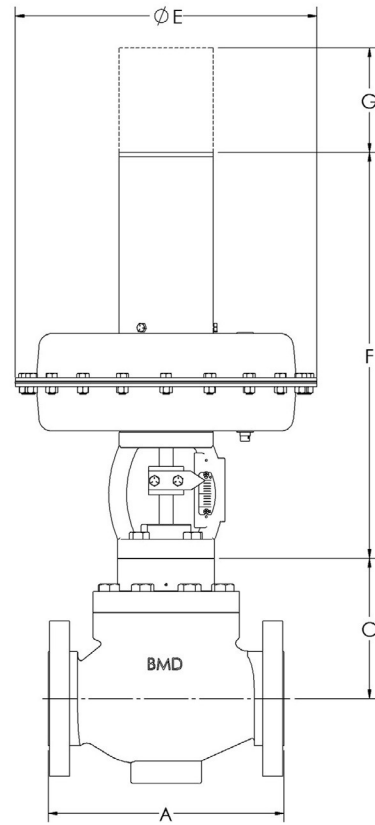
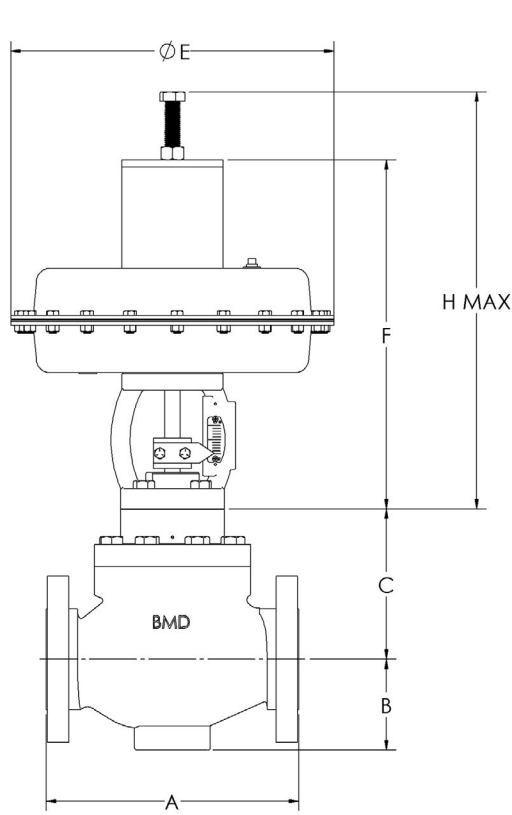

Weights

End Connection	CV30 Valve Weights							
	2" Globe		3" Globe		4" Globe		6" Globe	
	lbkg		lbkg		lbkg		lbkg	
NPT	90	41	- -		- -		- -	
ANSI 150	9543		184 84		272 123		450 204	
ANSI 300	9845		194 88		290 132		481 218	
ANSI 600	103 47		200 91		321 142		558 253	
ANSI 900	130 59		224 101		336 152		- -	
ANSI 1500	130 59		- -		- -		- -	

How to Order

Options are listed below. All configurations may not be available. Call your sales representative or FW Murphy for more information. Repair kits are available.

Example Model No. **CV30-2N50R73-1CB-1F**

CV30 Series Control Valve, 2" Globe Body, Threaded Ends, No. 70 Reverse Acting Actuator, 3-15 Spring, Standard Service, Carbon Steel with Buna Seals, Tool Steel Seat with Polyurethane Insert, Full Port

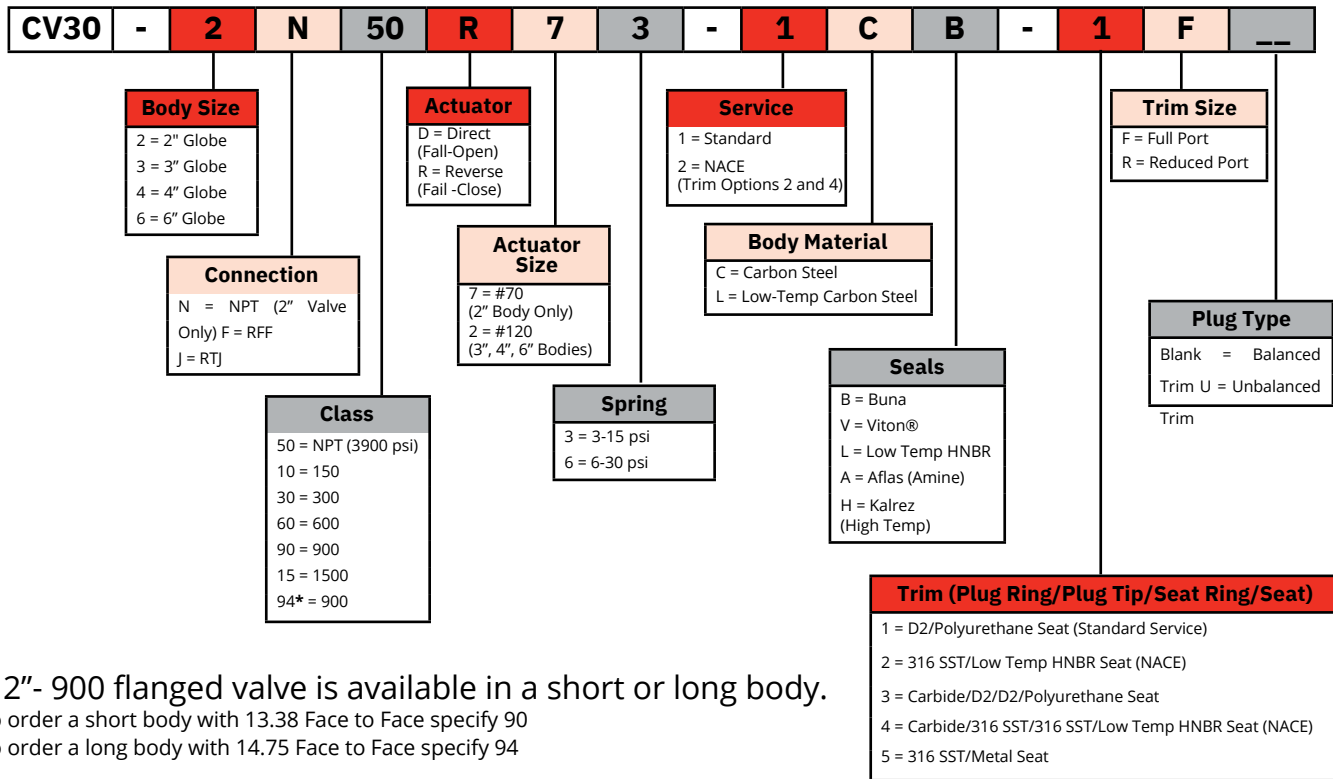

* 2"- 900 flanged valve is available in a short or long body.
To order a short body with 13.38 Face to Face specify 90
To order a long body with 14.75 Face to Face specify 94



CONTACT

✉ sales@rajkotmarine.com
☎ +971 6 7487580
🌐 www.rajkotmarine.com

RAJKOT MARINE LLC

Jerf Industrial Area 1,
P.O Box 5861
Ajman, UAE

